



Fresh Air Ventilation and Heat Exchange unit SAF-E4

- Model No.**
 SAF250E4
 SAF350E4
 SAF500E4
 SAF800E4
 SAF1000E4



Re; Building Regulations Part L2

The Part L2 (April 2006) regulations limit the amount of electrical/gas power to be used to provide heating or cooling in commercial buildings. Therefore the building designer needs to select energy efficient heating/cooling equipment, and to minimise energy losses through ventilation systems.

Capturing this waste energy, means the heating/cooling requirements of the building are reduced, so smaller size plant can be selected, savings can be made in long term energy consumption, and carbon emissions are reduced.

The SAF recovers heat energy which would otherwise be exhausted to atmosphere, and uses this energy to warm the air entering the building. The reverse happens in warmer climates, where the exhausted cool air is used to partially cool the incoming air.

The inclusion of the SAF energy recovery ventilation units in the building design, will reduce the total amount of carbon emissions.

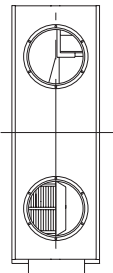

Structure (SAF1000E4)

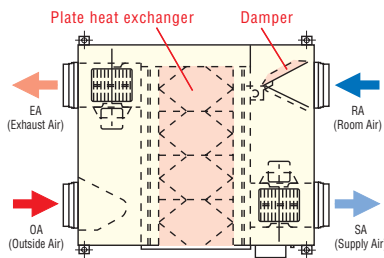

Principle of operation (simple ventilation)

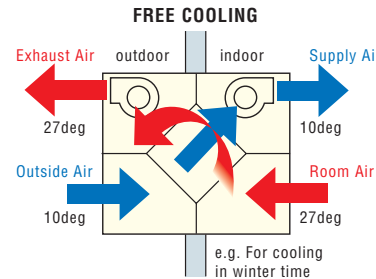

Principle of operation (heat exchanging)

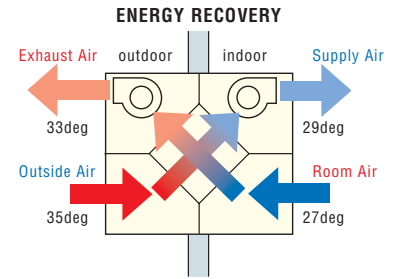

Specifications

Item	Model	SAF250E4	SAF350E4	SAF500E4	SAF800E4	SAF1000E4	
Power source		1 Phase 220-240V, 50Hz					
Exterior dimensions	mm	270x882x599	170x882x804	270x962x904	388x1322x884	388x1322x1135	
Height x Width x Depth							
Exterior appearance		Galvanised steel sheet					
Power input	W	99-114	124-137	169-188	309-359	360-399	
	Running current	A	0.46-0.48	0.59-0.60	0.79-0.81	1.48-1.50	1.85-1.93
Capacity	UHi	Enthalpy exchange efficiency	Cooling	63	66	62	65
		Enthalpy exchange efficiency	Heating	70	69	67	71
	Temperature exchange efficiency			75			
	Hi	Enthalpy exchange efficiency	Cooling	63	66	62	65
		Enthalpy exchange efficiency	Heating	70	69	67	71
	Temperature exchange efficiency			75			
Lo	Enthalpy exchange efficiency	Cooling	66	69	77	68	68
	Enthalpy exchange efficiency	Heating	73	71	67	74	73
	Temperature exchange efficiency			76			
Motor & Q'ty	kW	0.02x2	0.044x2	0.062x2	0.117x2	0.137x2	
Air handling equipment	Fan type & Q'ty	Sirocco fan x 2					
Air flow	UHi	250	350	500	800	1000	
	Hi	250	350	500	800	1000	
	Lo	170	280	370	650	810	
Available static pressure	UHi	90	95	105	140	90	
	Hi	80	65	70	110	55	
	Lo	37	42	38	70	35	
Air filter	Out take intake air	Protection for element (Washable) PS400					
	Exhaust air						

Dimensions

All measurements in mm.

SAF250E4,350E4,500E4

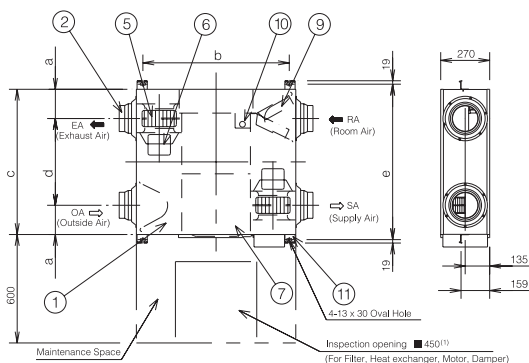

SAF800E4

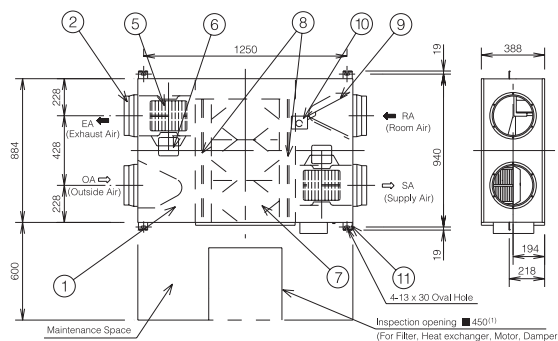

SAF1000E4

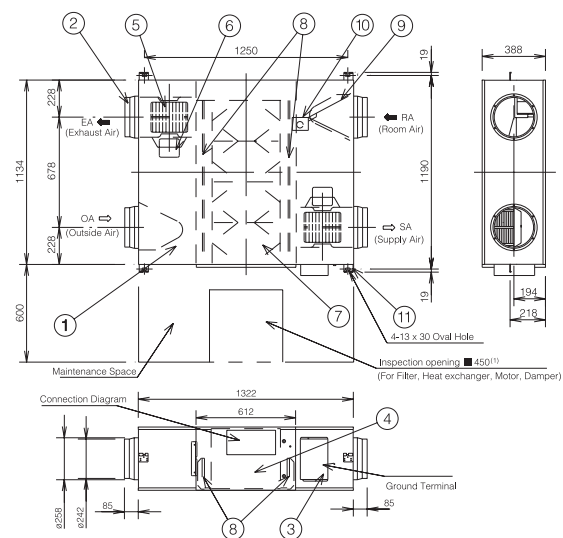

Installation reference

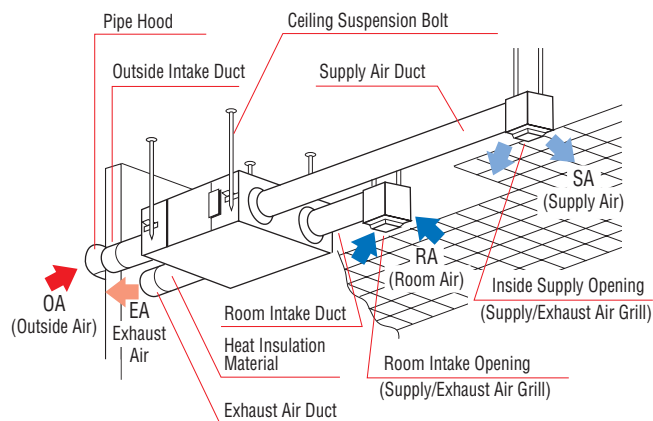

NO.	Name	Quantity	Material	Remarks
1	Frame	1	Zinc-plated steel	
2	Adaptor	4	ABS Resin	
3	Electrical Equipment Box	1		
4	Inspection Cover	1	Zinc-plated steel	
5	Fan	2	ABS Resin	
6	Motor	2		
7	Heat Exchange Element	2	Flame Retardant Paper + Plastic	Air to air Heat Exchanger
8	Filter	2	Non-woven Cloth	Collection Efficiency Gravimetric Method 82%
9	Damper	1		
10	Damper Motor	1		
11	Ceiling Suspension Fixture	4	Zinc-plated Steel	

Dimension table

Unit:mm

Model	a	b	c	d	e
SAF250E4	142	810	599	315	655
SAF350E4	162	810	804	480	860
SAF500E4	202	890	904	500	960

Model	f	g	h	i	j
SAF250E4	ø219	ø164	ø144	882	95
SAF350E4	ø219	ø164	ø144	882	95
SAF500E4	ø246	ø210	ø194	962	107

Note(1) An inspection port is needed for cleaning the heat exchanger and filter 1 or 2 times a year.